

1 2 3 4 5 6 7 8

REVISIONS			
ISS	ZONE	DESCRIPTION	APPROVED\DATE

業務部

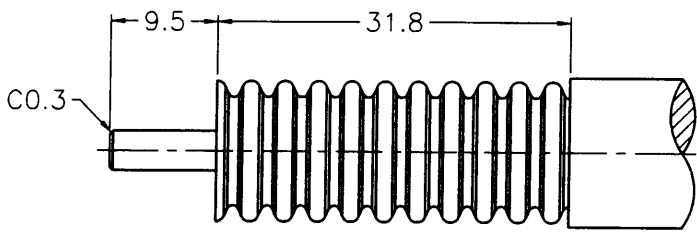

RECOMMENDED  
CABLE STRIPPING DIM'S  
(建議剝線尺寸)

F

E

D

C

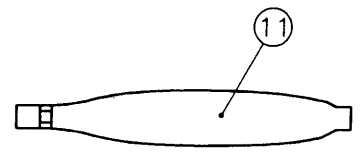
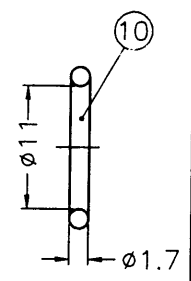
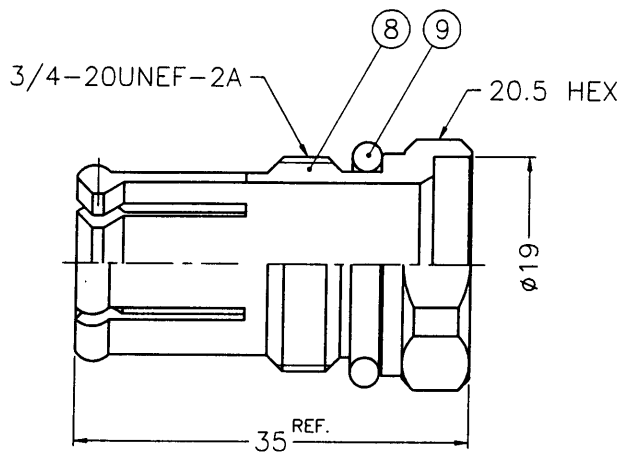
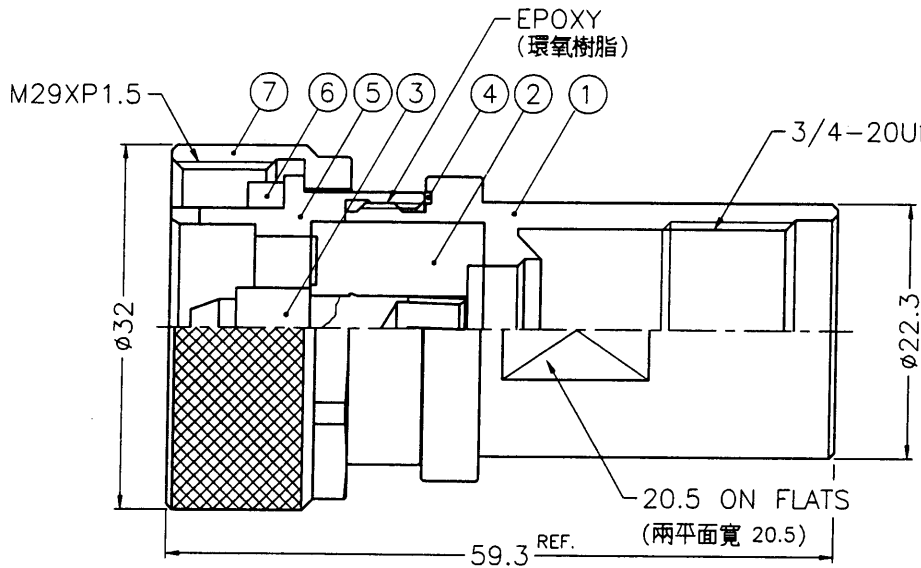

出國  
88.7.01  
& D

11	LUBRICATOR	NOTE 6	NOTE 6	1	N87070302-11
10	GASKET	SILICONE	RED	1	GS-144/11XD17
9	GASKET	SILICONE	RED	1	GS-21/158XD26
8	NUT	NOTE 1	NOTE 2	1	N87070302-7
7	SHELL	NOTE 1	NOTE 2	1	7161141A1-7
6	GASKET	SILICONE	RED	1	GS-25/205X35
5	CONTACT BODY	NOTE 1	NOTE 2	1	7161141A1-5-1/2A
4	GASKET	SILICONE	RED	1	GS-24/22XD1
3	CONTACT PIN	NOTE 3	NOTE 4	1	7161141A1-3-1/2A
2	INSULATOR	NOTE 5	NATURAL	1	7161141A1-2T-1/2A
1	BODY	NOTE 1	NOTE 2	1	7161141A1-1-1/2A
NO.	DESCRIPTION	MATERIAL	FINISH	Q'TY	DRAWING NO.

NOTES: FINISH (PLATING THICKNESS IN MICRO-INCHES)  
 1. BRASS PER QQ-B-626  
 2. COPPER-TIN-ZINC ALLOY  
 3. BERYLLIUM COPPER PER QQ-C-530  
 4. SILVER PL. 200 MIN. THICK OVER COPPER STRIKE  
 5. TEFLON MIL-P-19468  
 6. SILICONE GREASE PER POLYTEX 55-M OR EQUIVALENT

DIMENSIONS ARE IN MILLIMETERS  
 UNLESS OTHERWISE SPECIFIED TOLERANCES  
 0.5-6 = ±0.2  
 6-30 = ±0.4  
 30-120 = ±0.6  
 120-315 = ±1  
 315-1000 = ±1.6  
 1000-2000 = ±2.4

PART NO.	
APPROVED	DATE 06-28-99'
CHECKED	DATE 06-28-99'
DRAWN	DATE 06-28-99'

<p>KAI JACK INDUSTRIAL CO., LTD. TAINAN TAIWAN R.O.C.</p>	
TITLE 7/16 CLAMP PLUG (FOR ANDREW 1/2" LDF4-50A HELIAX CABLE)	
DRAWING NO. KJ-7161141A1-N/NTS-1/2A-50	
FILE NO. F:\DWG\716\1141A1\12A\NNTS	

A

1 2 3 4 5 6 7 8 8716 Rev3